

A02P is a TDOA (Time Difference of Arrival) general anchor in the IPS, designed by Nooploop independently. It can be used in industrial intelligence, warehousing and logistics, production safety, smart city, smart navigation and other scenarios.



Parameters	Typical
Model	A02P
Antenna	External Antenna
Product and Antenna Weight	600g + 59g
Dimensions	143*143*62mm
Shell Material	Cast Aluminium
Communication Interface	POE
Power Supply	POE(36~57V DC)
Power Consumption	3.0W
Number of Cascades	6, using standard 30W POE Switch, Cat5e cables, cascade length \leq 150m
UWB RF CH	CH5: 6489.6MHz, CH9: 7987.2MHz
Channel Bandwidth	499.2MHz
TX Power	[-46, -15]dBm/MHz@6.5G, [-42, -14]dBm/MHz@8.0G
Distance Range	Operating Conditions: 100m@6.5G, 60m@8.0G
Cold Start Time	1s
Operating Temperature	-40°C ~ 75°C
Storage Temperature	-40°C ~ 85°C
Operating Humidity	10% ~ 90% non-condensing
Ingress Protection	IP68
Interaction	Indicator Light
Tail Line Length	40cm

Structure

Dimensions

Unit: mm

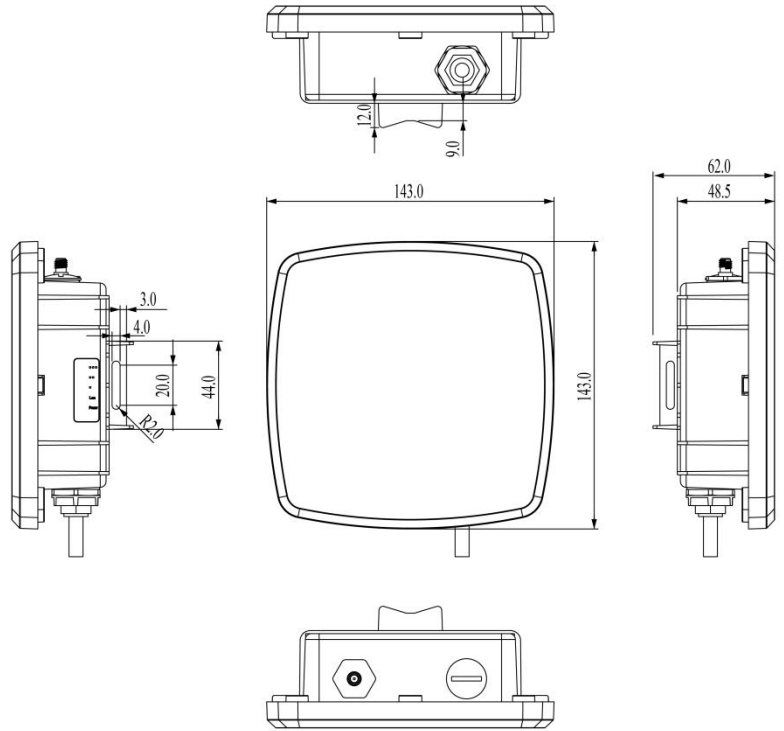
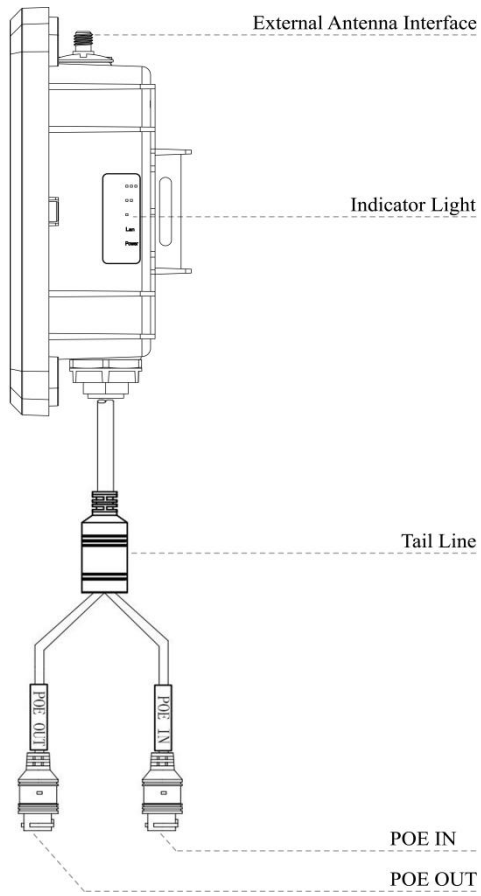

Note: The actual size may vary according to the manufacturing process and measurement method. Please refer to the actual product.

Contact

SZ Nooploop Technology Co.,Ltd.

Email: sales@nooploop.com

Tel: [+86-0755-86680090](tel:+86-0755-86680090)

Website: www.nooploop.com