

A02 is a TDOA (Time Difference of Arrival) general anchor in the IPS, designed by Nooploop independently. It can be used in industrial intelligence, warehousing and logistics, production safety, smart city, smart navigation and other scenarios.



Parameters	Typical
Model	A02
Antenna	Internal Antenna
Weight	420g
Dimensions	190*190*53mm
Shell Material	ABS+PC (Flame Retardant )
Communication Interface	POE (One input, one output)
Power Supply	POE (36~57V DC)
Power Consumption	3.0W
Number of Cascades	6, total length≤150m
UWB RF CH	CH5: 6489.6MHz, CH9: 7987.2MHz
Channel Bandwidth	499.2MHz
TX Power	[-46, -15]dBm/MHz@6.5G, [-42, -14]dBm/MHz@8.0G
Distance Range	Open space: 100m, typical: 50m
Operating Temperature	-30°C ~ 70°C
Storage Temperature	-40°C ~ 85°C
Operating Humidity	10% ~ 90% non-condensing
Ingress Protection	IP66
Surge Protection	Common-mode ±6kV, Differential-mode ±6kV
Interaction	Indicator Light
Tail Line Length	40cm

**Structure**

**Dimensions**

Unit: mm

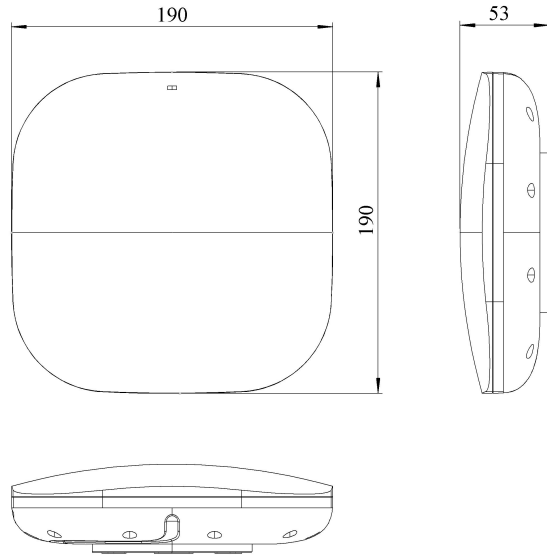
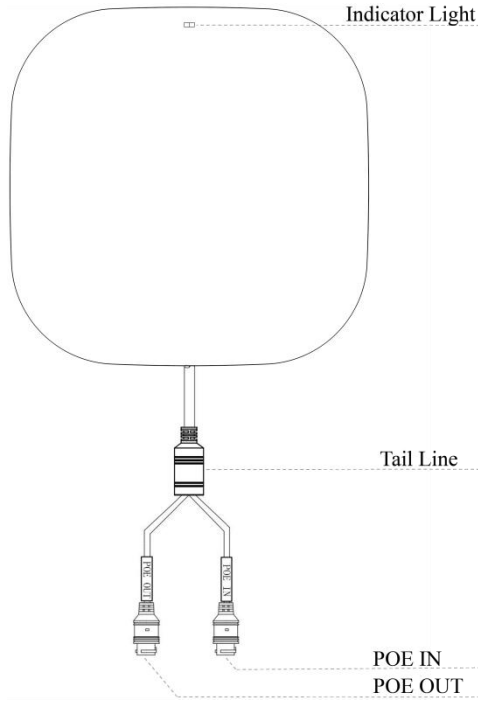

Note: The actual size may vary according to the manufacturing process and measurement method. Please refer to the actual product.

**Update Log**

Version	Update Note	Date
V2.1	*	20241212

**Contact**

SZ Nooploop Technology Co.,Ltd.

Email: [sales@nooploop.com](mailto:sales@nooploop.com)

Tel: [+86-0755-86680090](tel:+86-0755-86680090)

Website: [www.nooploop.com](http://www.nooploop.com)